



# PRODUCT SPECIFICATION

# 产品规范

适用于 For  
K802F GNSS 模块  
K802F GNSS Module



©2023, QinNav Technology Ltd. All rights reserved. QinNav is the trade mark of QinNav Technology Ltd, registered in People's Republic of China. All other trademarks are the property of their respective owners.

## REVISION HISTORY / 修订历史

Revision/版本	Modification/更改	Date/日期
1.0	New Release. / 新发	2023-09-04
1.1	Delete LDO paragraphs / 删除LDO段落	2023-11-28
1.2	Modify the description of pin 7 and modify the antenna power supply method / 修改7号引脚说明，并修改天线供电方式	2023-12-18

## DIRETORY / 目录

REVISION HISTORY / 修订历史.....	2
DIRETORY / 目录.....	3
1. Introduction / 简介.....	4
1.1. Product Characteristics / 产品特性.....	4
2. Size / 尺寸.....	9
3. Pin Arrangement and Definition / 针脚标识和定义.....	11
3.1. Remarks / 说明.....	13
4. Assembling & Repairing Note / 装配及维修说明.....	16
4.1. Module Assembling Note / 模块装配说明.....	16
4.2. Repairing Note / 维修说明.....	17
5. Application Connection Example / 应用连接示例.....	18
6. Package / 包装.....	21
Figures	
Figure 1. K802F Product Photo / K802F 实物图.....	9
Figure 2. K802F Dimension View / K802F 三视图.....	10
Figure 3. K802F Includes 54-Pin Pad / K802F 包括54连接焊盘.....	11
Figure 4. Furnace Temperature Curve / 炉温曲线.....	16
Figure 5. Connections between RS232 COM1, 2, 3 of K802F and Some Other Devices with An UART / K802F RS232 COM1、2、3与其他使用UART接口的设备之间的连接示意.....	18
Figure 6. Minimum Hardware Design of K802F / K802F 最小硬件设计.....	19
Figure 7. Recommend Design of K80F / K802F 推荐硬件设计.....	20
Figure 8. K802F Roll Tape Packing / K802F 卷带包装.....	21
Tables	
Table 1. Product Characteristics / 产品特性.....	4
Table 2. Pin Definition of K802F 54-Pin Pad / K802F 54针脚焊盘的针脚定义.....	11
Table 3. LVCMOS 3.3V Electrical Standard / LVCMOS 3.3V电气标准.....	13
Table 4. LVTTTL 3.3V Electrical Standard / LVTTTL 3.3V电气标准.....	13
Table 5. K802F Package Description / K802F 包装说明.....	21

# 1. Introduction / 简介

K802F is a small-sized, high-precision positioning module developed independently by ComNav for automotive-grade applications. Its main chip complies with AEC-Q100 standards, and production adheres to IATF16949 requirements. K802F supports multi-frequency signal tracking from various satellite navigation systems, including BDS-2, BDS-3, GPS, GLONASS, Galileo, QZSS and more. The module has on-board MEMS, it supports inertial navigation algorithms, and is suitable for intelligent driving market.

K802F 模块是司南导航自主研发的车规级、全系统多频点的小尺寸高精度定位模块，主芯片符合 AEC-Q100，生产符合 IATF16949，支持 BDS-2、BDS-3、GPS、GLONASS、Galileo、SBAS 和 QZSS 等卫星导航系统的信号跟踪，板载惯导器件，支持组合导航算法，适用于智能驾驶市场。

## 1.1. Product Characteristics / 产品特性

Table 1. Product Characteristics / 产品特性

Characteristics	K802F	
Automotive Grade 车规级	Main chip according to AEC-Q100 主芯片符合AEC-Q100	
Signals 信号	Positioning 定位	GPS: L1C/A, L2P, L2C, L5
		BDS-2: B1I, B2I, B3I*
		BDS-3: B1I, B1C, B2a, B2b, B3I*
		GLONASS: G1, G2*
		Galileo: E1, E5b, E5a, E6c*
		QZSS*: L1C/A, L2C, L5
		SBAS*: L1C/A, L5
		IRNSS*: L5
	Items with * will be adjusted with the version. 带*项会随同版本进行调整。	
Time to First Fix 首次定位时间	Cold Start 冷启动	<20s (Adding Acceleration Capture Module,增加捕获加速模块)
	Hot Start (with RTC)	<10s (Typical,典型)

	热启动 (使用RTC)	
Signal Capture 信号捕获	Reacquisition 失锁重捕	<1s
	Signals Tracking Sensitivity 信号跟踪灵敏度	-155dBm
	Signal Capture Sensitivity 信号捕获灵敏度	-138dBm
Measurement Precision 测量准确度	Pseudo-range Precision 伪距精度	≤10cm
	Carrier Phase Precision 载波相位精度	≤1mm
Accuracy 精度	PPS (RMS) 授时精度	20ns
	SPP Accuracy 标准单点定位精度	H≤1.5m, V≤3m (1σ, PDOP≤4)
	Static Differential Accuracy (Supported by Compass Solution) 静态差分精度 (Compass Solution软件支持)	H:±(2.5+1×10 <sup>-6</sup> ×D)mm V:±(5.0+1×10 <sup>-6</sup> ×D)mm D为基线长度 (单位: mm) D-Baseline length (Unit: mm)
	Speed Accuracy 测速精度	≤0.02m/s (1σ, PDOP≤4)
PPP	PPP Convergence Time PPP初始化时间	<15min
	PPP Accuracy PPP精度	H≤10cm, V≤20cm

RTK	RTK Initialization Time RTK初始化时间	<5s (D<10km)
	Initialization Reliability 初始化置信度	>99.9%
	RTK Accuracy RTK精度	H:±(8+10 <sup>-6</sup> ×D)mm V:±(15+10 <sup>-6</sup> ×D)mm D为基线长度(单位: mm) D-Baseline length (Unit: mm)
Anti-interference 抗干扰	K802F is built-in narrowband and continuous wave suppression algorithm engine K802F 内置窄带和连续波抑制算法引擎	
Inertial Navigation 组合导航	While the GNSS antenna signal is losing lock for 3 seconds, the accuracy maintains at centimeter level. While the GNSS antenna signal is losing lock for 10 seconds, the accuracy maintains at meter level. GNSS天线信号失锁 3s, 精度保持cm级 GNSS天线信号失锁 10s, 精度保持m级	
IMU	Gyroscope 陀螺仪	Measurement ranges 量程: ±125°/s
		Zero-biased repeatability 零偏重复性: 0.5°/s
		Zero-biased stability 零偏稳定性: 5°/h
		Angular random walk

		角度随机游走: $0.6^\circ/\sqrt{h}$
	Accelerometer 加速度计	Measurement ranges 量程: $\pm 2g$
		Total zero deviation 零偏重复性: 20mg
		Bias instability 零偏稳定性: 50ug
		Velocity random walk 速度随机游走: $0.42m/s/\sqrt{h}$
Data Rates 数据速率	Measurements & Position 测量&定位	Max 20Hz (Optional, 选配项)
	RTK: Positioning RTK: 定位	Max 20Hz (Optional, 选配项)
	IMU	Max 50Hz (Optional, 选配项)
Data Formats 输出数据格式	NMEA-0183	GPGGA, GPGSV, GPGLL, GPGSA, GPGST, GPHDT, GPRMC, GPVTG, GPZDA etc.
	ComNav Binary (CNB) 司南二进制格式	ComNav Self-Defined Binary 司南自定义二进制
	CMR(GPS)	CMROBS, CMRREF
	RTCM2.X	RTCM1, RTCM3, RTCM31
	RTCM3.X	1004~1008,1012,1019,1020,1033,1042,1045/1046, 1230 MSM3~MSM7:1073~1077,1083~1087,1123~1127,1093~1097

Electrical 电气特性	Voltage 供电电压	+ 3.3V~3.45V DC
	Power Consumption 功耗	0.8W
Environmental 环境要求	Operating Temperature 工作温度	-40°C~+85°C
	Storage Temperature 储存温度	-55°C~+95°C
Antenna Interface 天线接口	Impedance Matching 阻抗匹配	50Ω
	Antenna Power 天线供电电压	External 外部供电: +3.3V~+5V @ (0-100) mA
	Antenna Gain 天线增益	20~35dB
Hardware Interface 硬件接口	UARTx3, PPSx1, EVENTx1, I <sup>2</sup> Cx1, SPIx1	
Physical 物理参数	Size 尺寸	17mm×22mm×2.8mm
	Weight 重量	2.0g
	Flatness 平整度	≤ 0.1mm
	Package 封装	LGA (54PIN)



## 2. Size / 尺寸

In this section, product photo, three-side views and the dimension of K802F is provided for customers' further hardware design and installation.

本节提供了K802F的实物图，三视图和对应的物理尺寸，便于用户进一步系统硬件设计和安装。



Figure 1. K802F Product Photo / K802F 实物图



### 3. Pin Arrangement and Definition / 针脚标识和定义

K802F is surface-mount OEM Module which integrates 54 Pin (pitch 1.1mm).

K802F包括54Pin, 表贴式模块 (pitch 1.1mm)。

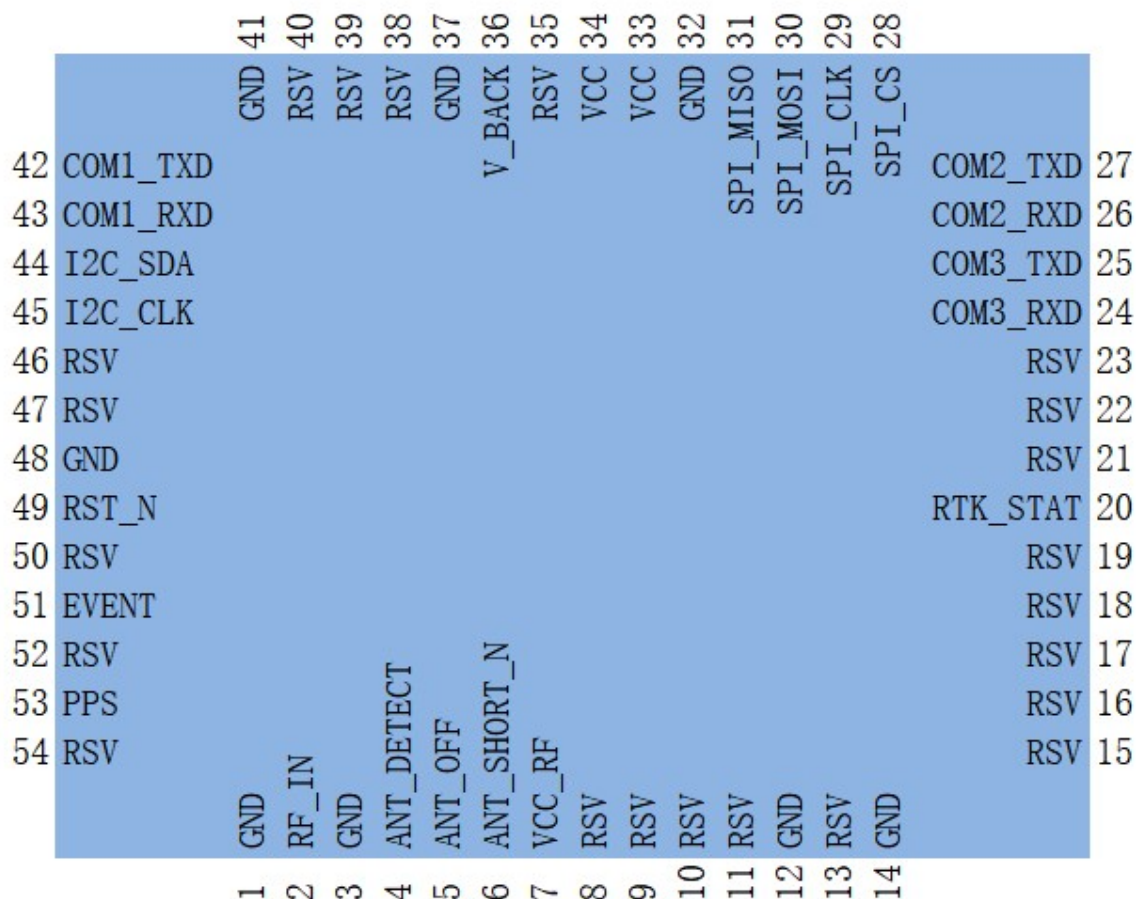

Figure 3. K802F Includes 54-Pin Pad / K802F 包括54连接焊盘

Table 2. Pin Definition of K802F 54-Pin Pad / K802F 54针脚焊盘的针脚定义

Pin	Signal	Type	Description	
1	GND	GND	Ground Reference	参考地
2	RF_IN	I	RF input	天线射频输入
3	GND	GND	Ground Reference	参考地
4	ANT_DETECT <sup>T*</sup>	I	Active antenna detect - default active high	天线开路检测-默认高电平
5	ANT_OFF <sup>*</sup>	O	External LNA disable - default active high	外部低噪放使能-默认高电平
6	ANT_SHORT_N <sup>*</sup>	I	Active antenna short detect - default active low	天线短路检测-默认高电平

©2023, QinNav Technology Ltd. All rights reserved. QinNav is the trade mark of QinNav Technology Ltd, registered in People's Republic of China. All other trademarks are the property of their respective owners.

Pin	Signal	Type	Description	
7-11	RSV	-	Reserved	保留管脚
12	GND	GND	Ground Reference	参考地
13	RSV	-	Reserved	保留管脚
14	GND	GND	Ground Reference	参考地
15-19	RSV	-	Reserved	保留管脚
20	RTK_STAT	O	RTK data LED indicator	在接收差分信号时会输出高电平脉冲，其他状态输出低电平
21-23	RSV	-	Reserved	保留管脚
24	COM3_RXD	I	UART3 input	串口3输入
25	COM3_TXD	O	UART3 output	串口3输出
26	COM2_RXD	I	UART2 input	串口2输入
27	COM2_TXD	O	UART2 output	串口2输出
28	SPI_CS	I/O	SPI_CS	SPI总线片选信号
29	SPI_CLK	I/O	SPI_CLK	SPI总线时钟信号
30	SPI_MOSI	I	SPI_MOSI	SPI主输出从输入信号
31	SPI_MISO	O	SPI_MISO	SPI主输入从输出信号
32	GND	GND	Ground Reference	参考地
33	VCC	PWR	Voltage supply	电源输入
34	VCC	PWR	Voltage supply	电源输入
35	RSV	-	Reserved	保留管脚
36	V_BACK	PWR	Backup supply voltage	备用电源输入
37	GND	GND	Ground Reference	参考地
38-40	RSV	-	Reserved	保留管脚
41	GND	GND	Ground Reference	参考地
42	COM1_TXD	O	UART1 output	串口1输出
43	COM1_RXD	I	UART1 input	串口1输入
44	I <sup>2</sup> C_SDA	I/O	I <sup>2</sup> C Data	I <sup>2</sup> C数据
45	I <sup>2</sup> C_CLK	I/O	I <sup>2</sup> C Clock	I <sup>2</sup> C时钟
46-47	RSV	-	Reserved	保留管脚
48	GND	GND	Ground Reference	参考地
49	RST_N	I	RESET_N	复位
50	RSV	-	Reserved	保留管脚
51	EVENT	I	External Interrupt Pin	外部中断输入
52	RSV	-	Reserved	保留管脚
53	PPS	O	Pulse Per Second	秒脉冲
54	RSV	-	Reserved	保留管脚
With * features under development, currently not supported. 带*项功能开发中，暂不支持				

### 3.1. Remarks / 说明

#### 1. Electrical Characteristics / 电气特性

COM1/2/3(TX&RX), SPI, ANT(DETECT&OFF&SHORT\_N), I<sup>2</sup>C, RST\_N, PPS, EVENT and RTK\_STAT are LVCMOS 3.3V. All these signals are compatible with LVCMOS / LVTTTL 3.3V.

COM1/2/3 (TX&RX) , SPI, ANT (DETECT&OFF&SHORT\_N) , I<sup>2</sup>C, RST\_N, PPS, EVENT和RTK\_STAT为LVCMOS 3.3V 电平, 所有这些信号均兼容 LVCMOS / LVTTTL 3.3V。

Table 3. LVCMOS 3.3V Electrical Standard / LVCMOS 3.3V电气标准

Symbols 符号	Description 描述	Min 最小	Max 最大
V <sub>IH</sub>	Input high voltage 输入高电压	2.0V	VCC+0.3V
V <sub>IL</sub>	Input low voltage 输入低电压	-0.3V	0.8V
V <sub>OH</sub>	High-level output voltage 高电平输出电压	VCC-0.4V	--
V <sub>OL</sub>	Low-level output voltage 低电平输出电压	--	0.41V
I <sub>OH</sub>	Sourcing current 拉电流		8mA
I <sub>OL</sub>	Sinking current 灌电流		8mA

Table 4. LVTTTL 3.3V Electrical Standard / LVTTTL 3.3V电气标准

Symbols 符号	Description 描述	Min 最小	Max 最大
V <sub>IH</sub>	Input high voltage 输入高电压	2.0V	VCC+0.3V
V <sub>IL</sub>	Input low voltage 输入低电压	-0.3V	0.8V
V <sub>OH</sub>	High-level output voltage 高电平输出电压	VCC-0.4V	--
V <sub>OL</sub>	Low-level output voltage 低电平输出电压	--	0.41V
I <sub>OH</sub>	Sourcing current 拉电流		8mA
I <sub>OL</sub>	Sinking current 灌电流		8mA

#### 2. Can withstand Voltage Range / 能承受的电压范围

The signal with the maximum voltage range from -0.3V to 3.6V is as follows: COM1/2/3(TX&RX), SPI, ANT(DETECT&OFF&SHORT\_N), I<sup>2</sup>C, RST\_N, PPS, EVENT and RTK\_STAT.

所能承受电压的最大值范围是 -0.3V~3.6V 的信号如下：COM1/2/3 (TX&RX) , SPI , ANT

(DETECT&OFF&SHORT\_N) , I<sup>2</sup>C, RST\_N, PPS, EVENT和RTK\_STAT。

### 3. Supply Voltage / 供电电压

VIN main power supply, voltage range: 3.3V~3.45V (DC), voltage ripple and spikes require less than 50mV. K802: ANT\_PWR, voltage range: 3.3V ~ 5.5V (DC), voltage ripple and spikes require less than 50mV. V\_BACKUP operating voltage 1.8V~3.6V, voltage ripple and spike pulse requirements are less than 30mV; When charging the Farrah capacitor, V\_BACKUP voltage reference circuit, voltage ripple and spike pulse requirements are less than 30mV.

VIN主供电电源，电压范围：3.3V~3.45V（直流），电压纹波和尖峰脉冲要求小于50mV。K802: ANT\_PWR，电压范围：3.3V~5.5V（直流），电压纹波和尖峰脉冲要求小于50mV。V\_BACKUP工作电压1.8V~3.6V，电压纹波和尖峰脉冲要求小于30mV；给法拉电容充电时，V\_BACKUP电压参考电路，电压纹波和尖峰脉冲要求小于30mV。

### 4. Add Surge Protection / 增加浪涌保护

In order to effectively protect against lightning strikes and surges, and prevent damage to the feed current limiting chip inside the module, it is recommended that users supply power to the antenna from outside the module and increase the surge protection function.

If you need to feed the antenna from the outside, it is recommended to use a high-voltage, high-power feeder chip; or add high-power protection devices such as gas discharge tubes, varistors, and TVS tubes to the feeder circuit.

为了有效防雷击、防浪涌，防止模块内部的馈电限流芯片损坏,建议用户从模块外部给天线供电并增加浪涌保护功能。

如需从外部为天线馈电，建议选用高耐压、大功率的馈电芯片；或在馈电电路上增设气体放电管、压敏电阻、TVS管等大功率的防护器件。

### 5. Hardware Integration Considerations / 硬件集成注意事项

- 1) VCC power-on has a good monotonicity, and the initial level is lower than 0.4V, and the upstroke and ringing are guaranteed within the range of 5% VCC;
- 2) Use the VCC pin to provide a reliable power supply and all GND pins of the module are grounded;
- 3) Connect the ANT\_IN signal to the antenna, pay attention to the 50Ω impedance matching of the line;
- 4) The ANT pin of the module cannot directly power the antenna, and an external power supply is required;
- 5) The module reset pin FRESET\_N is for restoring the factory settings of the module, and RST\_N is for quick reset. Please connect it correctly to ensure that the module can be reset reliably;
- 6) Antenna interface: The antenna line is as short and smooth as possible, avoiding acute angles; pay attention to 50Ω impedance matching;
- 7) Avoid wiring directly under K802F;
- 8) The module is as far away from the high temperature airflow as possible.

- 1) VCC上电具有良好的单调性，且起始电平低于0.4V，上冲与振铃保障在5%VCC范围内；
- 2) 用VCC引脚提供可靠的电源且模块所有GND引脚接地；
- 3) 连接ANT\_IN信号至天线,注意线路50Ω阻抗匹配；

- 4) 模块ANT引脚不能直接给天线供电，需要外接供电；
- 5) 模块复位引脚FRESET\_N为恢复模块出厂设置，RST\_N为快速复位，请正确连接以保证模块可以可靠复位；
- 6) 天线接口：天线线路尽量短且顺畅，避免走锐角；注意50Ω阻抗匹配；
- 7) 避免在K802F正下方走线；
- 8) 模块尽量远离高温气流。

## 6. Static Electricity Protection / 静电保护

Some components on K802F module are easily damaged by static electricity, which in turn affects the IC circuit and other components. Therefore, you should pay attention to electrostatic protection measures when using it.

- 1) When handling the module, try to wear gloves or finger cots and an anti-static wrist strap that meets the electrostatic protection standards;
- 2) During the process of taking the module, only the edge of the board should be taken, and the solder joints, circuit parts or components should not be directly touched to avoid sweat fingerprints from contaminating the solder joints;
- 3) The module should be protected by a soft protective pad between the module and the module interval during transportation;
- 4) When the module is idle, it should be placed on a soft protective pad (such as anti-static sponge pad, etc.), and do not stack at will;
- 5) The modules should be placed neatly and orderly, with a certain interval between modules to avoid collision with each other;
- 6) The module should be handled with care during use to prevent the module from being damaged by rough operation;
- 7) When powering on, pay attention to the positive and negative poles of the power supply and the voltage to avoid reverse connection and excessive voltage from burning the module;
- 8) When soldering the module to the motherboard, please ensure that the GND is soldered first, and then the ANT\_IN pin;
- 9) When handling ANT\_IN pin, do not touch any live capacitance or material (e.g., surface mount antenna, coaxial cable, wire iron, etc.) to avoid damage to the ANT\_IN pin by the charge generated or stored by said capacitor or material;
- 10) Please make sure to solder the ANT\_IN pin with an electrical protection iron.

K802F模块上的部分元器件易受静电影响而损坏，进而影响IC电路及其他元件。因此在使用时应注意做好静电保护措施。

- 1) 拿取模块时应尽量戴好手套或者指套以及符合静电防护标准的防静电腕带；
- 2) 模块拿取过程中应只拿取板卡的边缘部位，不能直接接触焊点，线路部分或者元器件，避免汗液指印污染焊点；
- 3) 模块在运输过程中模块与模块间隔之间应该采用软性防护垫进行保护；
- 4) 模块闲置时应放置在软性防护垫上（如防静电海绵垫等），不要随意堆叠；
- 5) 模块摆放应摆放整齐有序，模块之间保持一定间隔，避免相互碰撞；
- 6) 模块在使用过程中应该轻拿轻放，防止粗暴作业损坏模块；
- 7) 上电时，注意电源正负极以及电压，避免反接和电压过高烧毁模块；
- 8) 将模块焊接到主板时，请确保GND先焊接，然后再焊接ANT\_IN引脚；
- 9) 处理ANT\_IN引脚时，请不要接触任何带电电容或材料（例如表贴天线、同轴电缆、电烙铁等），以免所述电容或材料所产生或存储的电荷损坏ANT\_IN引脚；
- 10) 请确保使用带电保护的电烙铁焊接ANT\_IN引脚。

## 4. Assembling & Repairing Note / 装配及维修说明

### 4.1. Module Assembling Note / 模块装配说明

K802F is surface mounted, SMT welding is recommended for assembly.

K802F为表贴式模块，推荐使用SMT的焊接方式进行装配。

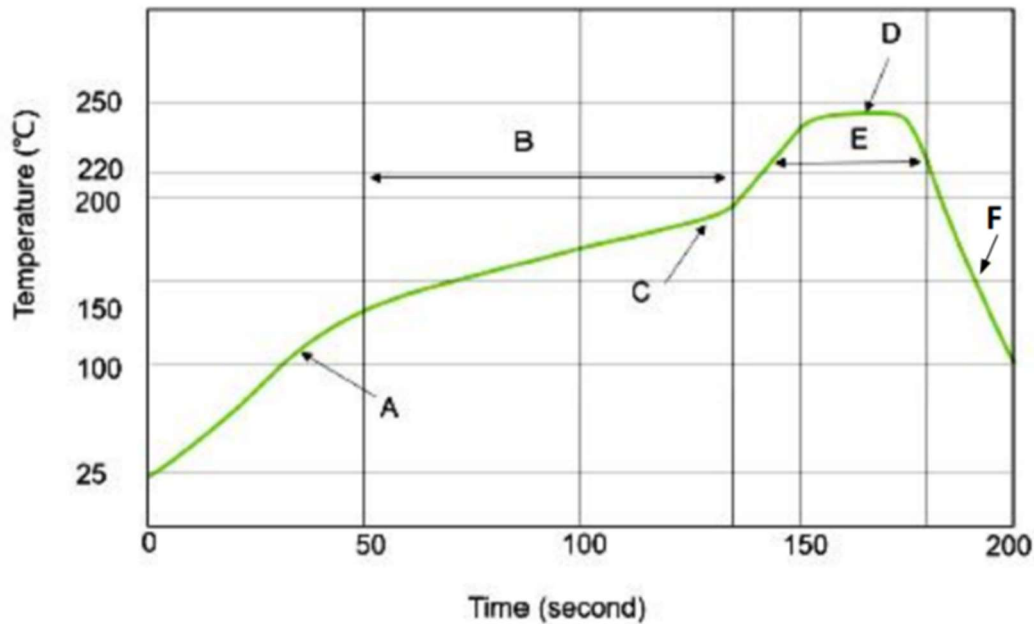

Figure 4. Furnace Temperature Curve / 炉温曲线

The process temperature limits are as follows:

- A: Heating Zone: Rising Slope:  $1 \sim 3^{\circ}\text{C} / \text{sec}$
- B: Constant Temperature Zone: Range:  $150 \sim 190^{\circ}\text{C}$  Time:  $80 \sim 110\text{ S}$
- C: Constant Temperature  $\rightarrow$  Reflow Zone: Rising Slope:  $1 \sim 3^{\circ}\text{C} / \text{sec}$
- D: Peak Temperature:  $235 \sim 245^{\circ}\text{C}$
- E: Reflow Zone: Range: Over  $220^{\circ}\text{C}$  Time:  $50 \sim 80\text{ S}$
- F: Descent Slope:  $-5^{\circ}\text{C} \sim -1^{\circ}\text{C} / \text{sec}$

制程温度界限如下：

- A: 升温区：斜率： $1 \sim 3^{\circ}\text{C} / \text{sec}$
- B: 恒温区： $150 \sim 190^{\circ}\text{C}$  时间： $80 \sim 110\text{S}$
- C: 恒温 $\rightarrow$ 回流区：斜率： $1 \sim 3^{\circ}\text{C} / \text{sec}$
- D: 峰值温度： $235 \sim 245^{\circ}\text{C}$
- E: 回流区：大于 $220^{\circ}\text{C}$  时间： $50 \sim 80\text{S}$
- F: 下降斜率： $-5 \sim -1^{\circ}\text{C} / \text{sec}$



In order to prevent the module from being damaged by repeated heating, it is recommended to place the module after finishing the first side of PCB board.

为避免模块因反复受热而损坏，建议在完成PCB板第一面的回流焊之后再贴模块。

#### 4.2. Repairing Note / 维修说明

When disassembling the module, it is suggested using a BGA welding bench. Please use correct air tuyere and choose certain temperature curve. Keep peak temperature under 245°C, rising slope under 3°C/s.

拆卸模块时，请使用BGA返修台，选择适合尺寸的风嘴并使用合适的温度曲线，最高温度不超过245°C，升温斜率不超过3°C/s。

## 5. Application Connection Example / 应用连接示例

In this section, an application connection example of K802F OEM Module is presented via specific schematic diagrams. Per the instruction of these diagrams, you could easily build the communication circuits between K802F OEM Module and other terminals such as PC, GPRS or Bluetooth module, and some other devices with an UART.

本部分以具体电路的形式提供一个K802F模块应用连接示例。参照下面的图示，您可以很方便建立K802F模块和其他终端（如PC，GPRS模块，蓝牙模块或其他带有UART的设备）之间的通讯电路。

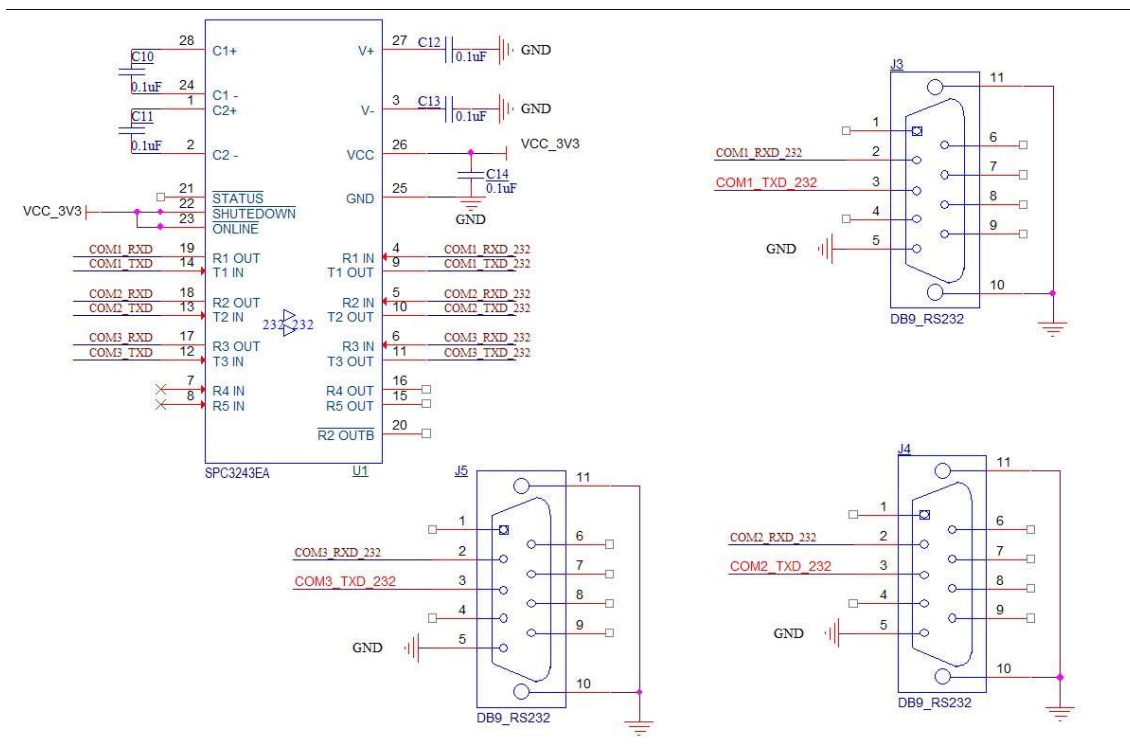

Figure 5. Connections between RS232 COM1, 2, 3 of K802F and Some Other Devices with An UART / K802F RS232 COM1、2、3与其他使用UART接口的设备之间的连接示意

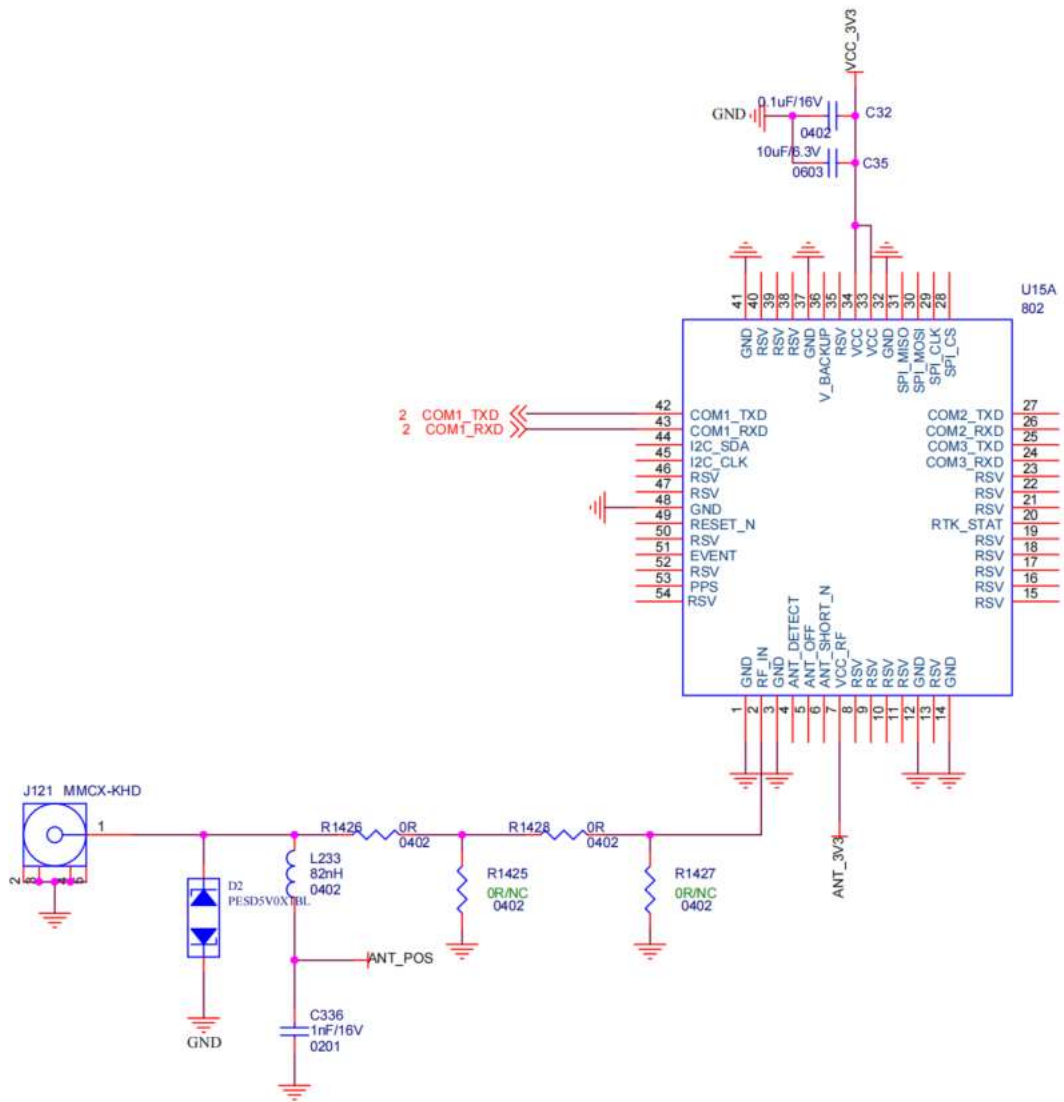

Figure 6. Minimum Hardware Design of K802F / K802F 最小硬件设计

©2023, QinNav Technology Ltd. All rights reserved. QinNav is the trade mark of QinNav Technology Ltd, registered in People's Republic of China. All other trademarks are the property of their respective owners.

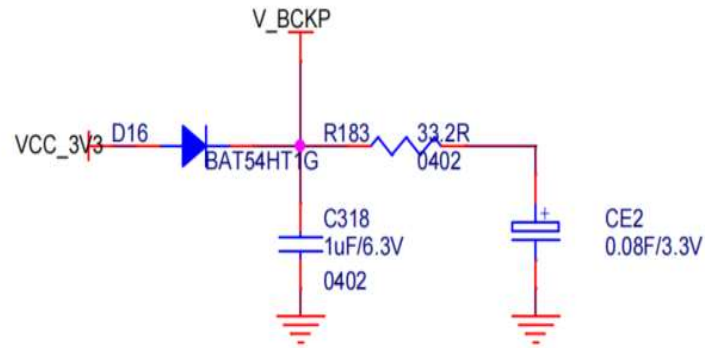

Figure 7. Recommend Design of K802F / K802F 推荐硬件设计

## 6. Package / 包装

K802F module is packaged in a vacuum-sealed aluminum foil electrostatic bag containing desiccant and moisture proof by means of carrier tape and coil (applicable to mainstream surface mount equipment). When welding modules by reflow soldering process, please strictly comply with IPC standards for humidity control of modules. Because the packing materials such as the carrier belt can only withstand 55°C, the modules need to be removed from the packaging during baking operation.

K802F 模块使用载带、卷盘方式（适用于主流表面贴装设备），包装在真空密封的铝箔防静电袋中，内含干燥剂防潮。采用回流焊工艺焊接模块时，请严格遵守 IPC 标准对模块进行湿度管控。由于载带等包装材料只能承受 55°C，在进行烘烤作业时需要将模块从包装中取出。

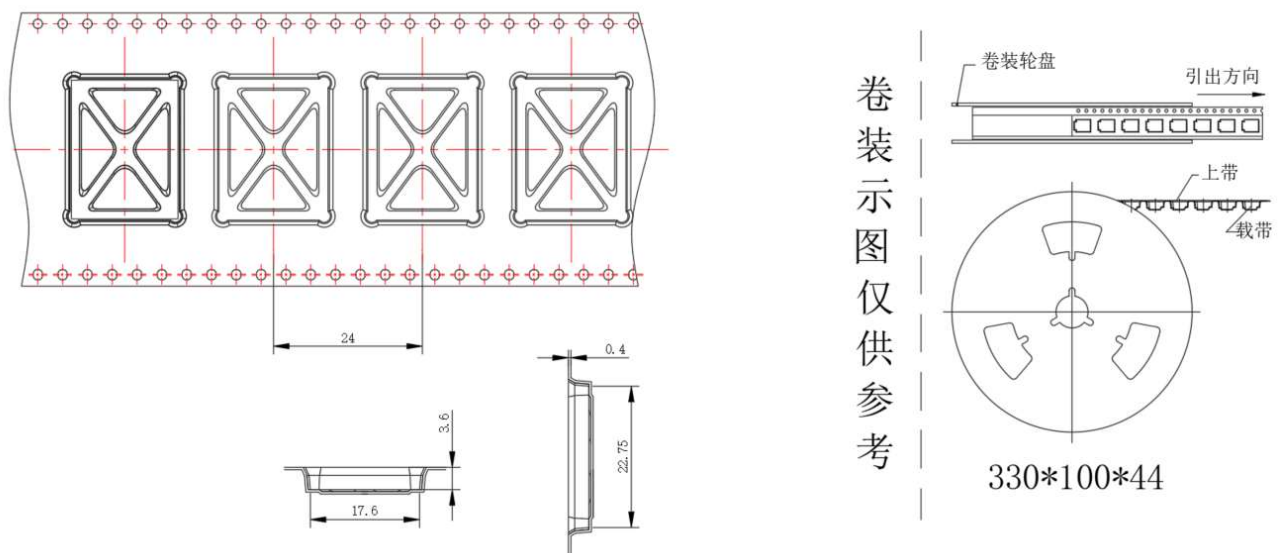

Figure 8. K802F Roll Tape Packing / K802F 卷带包装

Table 5. K802F Package Description / K802F 包装说明

Project	Description
Number of Modules 模块数量	600 Slice/Roll 600 片/卷
Reel Size 卷盘尺寸	Material tray:13 inches 料盘: 13 寸 Outer diameter: 330mm, inner diameter: 100mm, width: 44mm, wall thickness: 3.6mm 外径 330mm, 内径 100mm, 宽 44mm, 壁厚 3.6mm

	Package of each module: length 22.75mm, width 17.6mm 每个模块包装: 长 22.75mm, 宽 17.6mm
Carrier Belt 载带	Module Spacing (Center Distance): 24mm 模块间距 (中心距) : 24mm

### 上海钦天导航技术有限公司

QinNav Technology, LTD.

上海市嘉定区澄浏中路618号1号楼B区6楼

6th Floor, Zone B, Building 1, 618 Chengliu Middle Road, Jiading District, Shanghai

官方网站: [www.qinnav.com](http://www.qinnav.com)

邮箱: [qinnav@qinnav.com](mailto:qinnav@qinnav.com)

热线: 400-060-8030



司南导航

QinNav  
钦天导航